

**1.9205.04.3.IS**

**NANOBAR 25mm WALL MIXER AND SPOUT  
INSTALLATION INSTRUCTIONS**

## **IMPORTANT INFORMATION:**

- For servicing the cartridge, isolate the water supply, remove the handle, remove the locknut from on top of the cartridge and remove the cartridge. Do not overtighten the locknut when reinstalling. The locknut should be tightened firmly, but not excessively.
- All tapware and plumbing must be tested for leaks and functionality before sheeting off / concealing the wall as per AS3500. This includes independently testing the hot and cold operation of the mixer.
- Water pressure must not exceed 500kpa as per AS3500, or the product warranty will be void.
- Pressure difference between hot and cold must not exceed 150kpa.
- This product is designed to work on high pressure systems only.
- Before sheeting the walls it is important that the system is checked for water hammer. If water hammer is apparent, all possible measures are to be taken, including but not limited to ensure pipework is correctly secured, keeping the length of the pipework from the outlet as short as possible, and the fitting of outlets which have a high star rating. Ensure that water pressure is not exceeding 500kpa, ensuring the correct pipe size is installed. Install an air chamber or water hammer arrestor if required.
- Ensure wall sheets and tiles are installed as close to the waterproofing sleeve as possible.
- Ensure waterproofing sleeve is not deformed. If the waterproofing sleeve is deformed by wall linings, the trim kit will not be able to be installed.
- Use of the provided insulation is optional. If the insulation is not used, Brodware recommend using another form of acoustic barrier around the body / breech.

## NANOBAR WALL MIXER AND SPOUT - INSTALLATION GUIDE

---

### ROUGH IN PROCESS

1. Set-back for rough in of the mixer body assembly is 65mm – 80mm, from the back of the mixer body assembly to the finished wall face (Fig.B). NOTE: If the optional 1.9305.BK.0.00 Adjustable Install Kit is being used, add 2mm to the set-back to accommodate the kit.
2. As per Fig. A, the hot inlet port is on the bottom left, the cold inlet port is on the bottom right, and the 3/8" female thread outlet port is on the far left. The mixer body should always be installed with the 3/8" female thread outlet port on the far left.
3. Remove the insulation. Secure the assembly to a noggin in the desired installation location and position by screwing through the 4 black rubber bushes on each corner of the mounting plate. We suggest using a pan head screw with a loose washer (Fig.A).
4. Flush water Lines. Connect plumbing. Test as per AS3500. Check operation and test for leaks before plastering or tiling. (If water hammer is apparent, please refer to the "IMPORTANT INFORMATION" section of this instruction booklet)
5. Refit the insulation (optional – refer to the "IMPORTANT INFORMATION" section of this installation instruction). Ensure the waterproofing sleeve is screwed down fully over the o-ring to ensure a positive seal. Press the sleeve cap into the waterproofing sleeve (Fig. B).
6. Sheet the wall. Waterproof to the waterproofing sleeve. Waterproofing membrane should be applied on both sides of the waterproofing aid supplied. **NOTE: the waterproofing aid is optional for installation. Assess if this should be used on your installation. All waterproofing liability is with the installer.**
7. Finish concealing the wall.

### FINAL FIT OFF PROCESS

1. Cut down the waterproofing sleeve flush with the finished wall face (Fig.D). Hold the waterproofing sleeve in position while cutting, to ensure that the waterproofing sleeve does not unscrew from inside the wall. Do not cut the internal o-ring, as this will prevent the trim kit from being fitted. Apply silicone between the waterproofing sleeve and the wall face.
2. Press fit mixer sleeve onto mixer body. Press fit the mixer trim onto mixer sleeve until it is pressing flush against the finished wall face.
3. Screw the locknut cover into the brass nut on the mixer body. Fit the handle to the mixer with the lever pin pointing up. Secure in place with grub screw and allen key.
4. Trial fit the spout nipple through the hole of the spout base. Remove the spout nipple and cut down to suit (if required). Apply thread tape to the male thread of the spout nipple. Feed the male thread through the hole in the cover plate and tighten firmly against the cover plate.
5. Press fit the spout cover plate over the spout base. Place spout retainer onto the spout nipple. Press the spout piece onto the spout nipple. Secure spout piece to spout nipple with the retainer screw.
6. Test the operation of the handle and check for leaks.

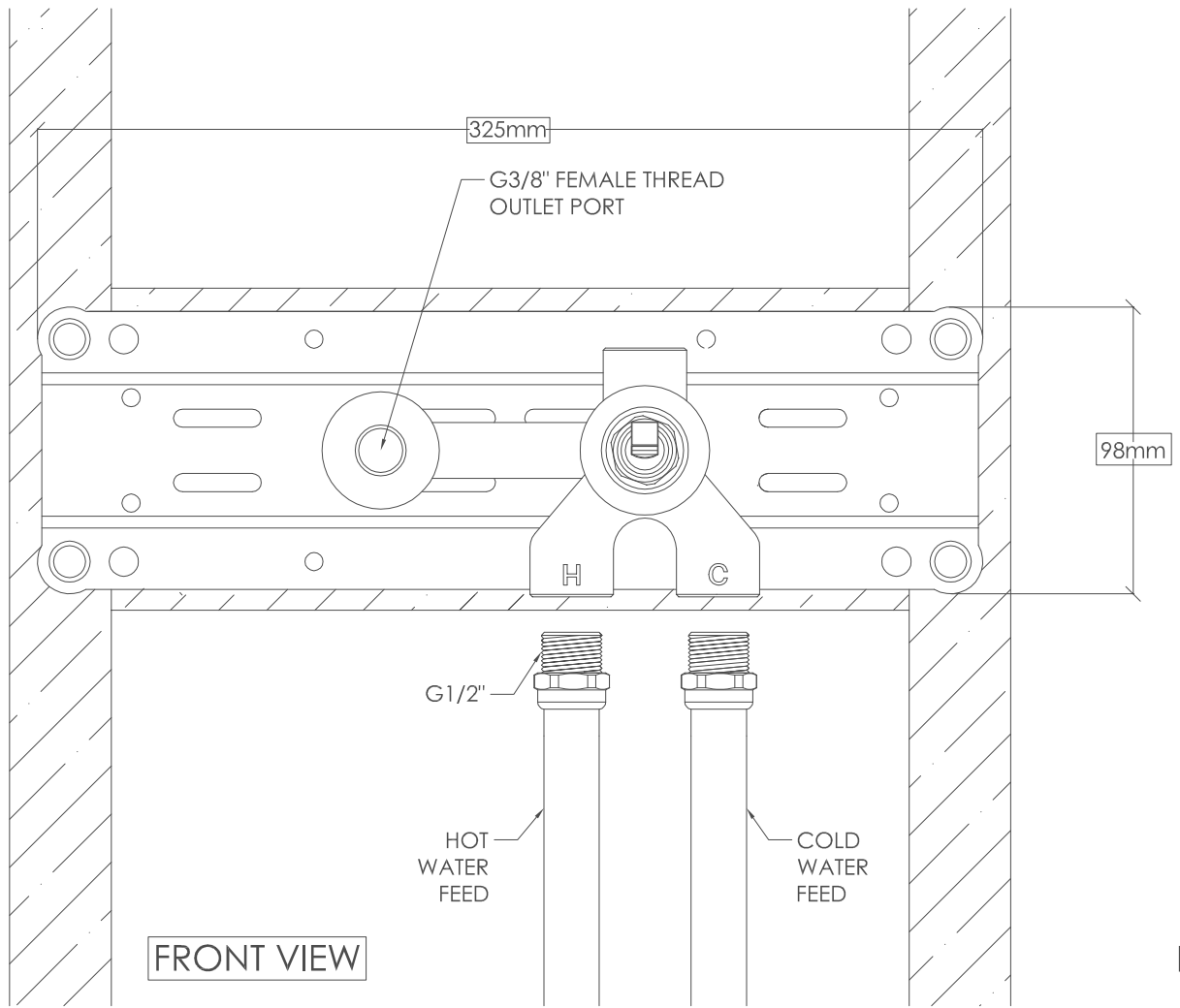

Fig.A

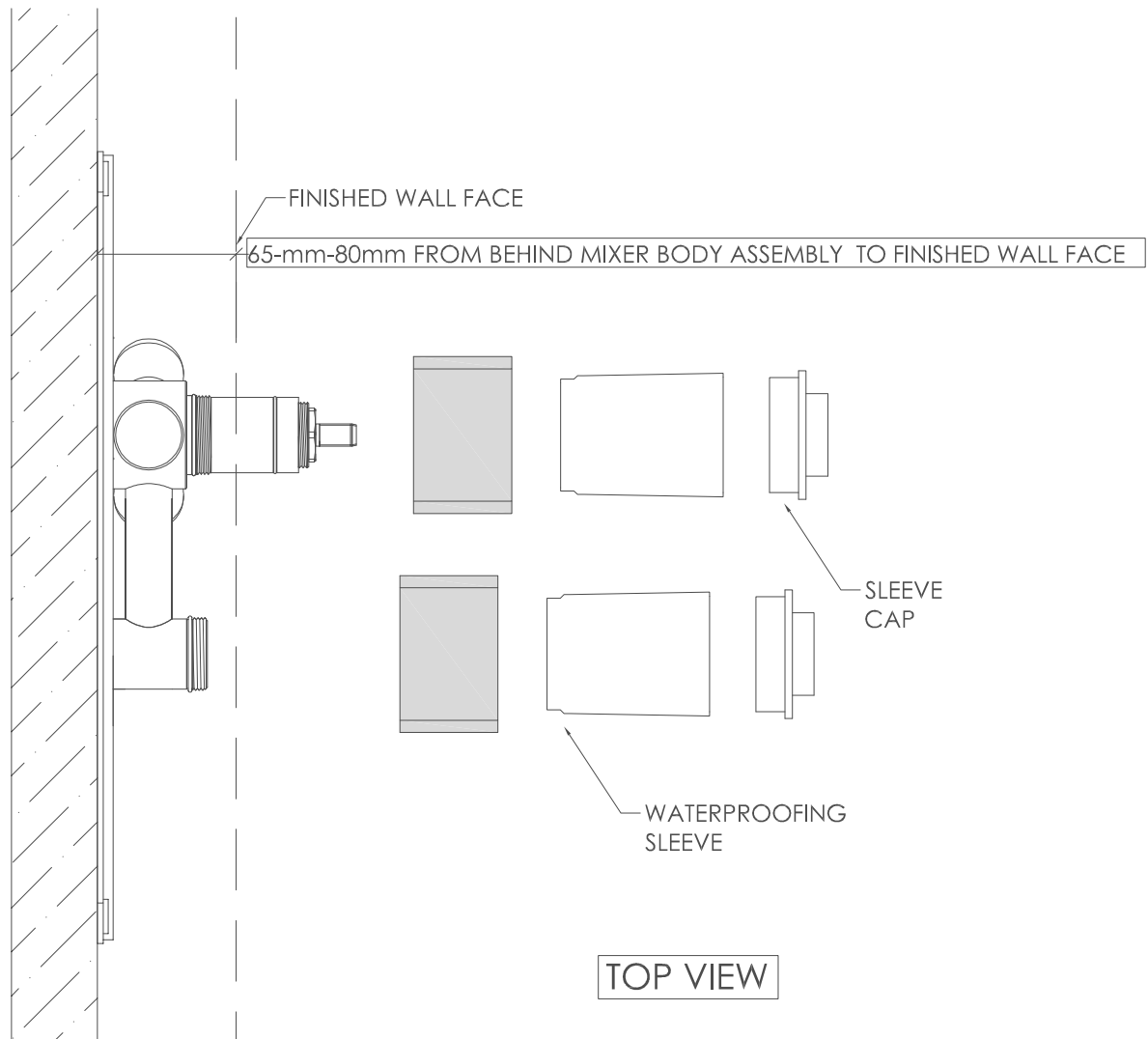

Fig.B

